



Europäisches Patentamt  
 European Patent Office  
 Office européen des brevets



AP

Publication number: **0 320 480 B1**

**EUROPEAN PATENT SPECIFICATION**

- (45) Date of publication of patent specification: 25.11.92 (51) Int. Cl.<sup>5</sup> B01F 5/22, B30B 11/22
- (21) Application number: 88850414.9
- (22) Date of filing: 08.12.88

(54) An apparatus for producing a mixture from liquid and powder ingredients, and kneading and extruding the mixture.

- (30) Priority: 11.12.87 SE 8704949
- (43) Date of publication of application: 14.06.89 Bulletin 89/24
- (49) Publication of the grant of the patent: 25.11.92 Bulletin 92/48
- (64) Designated Contracting States: AT BE CH DE ES FR GB GR IT LI LU NL
- (56) References cited:
 

EP-A- 0 163 619	DE-B- 1 085 851
FR-A- 2 119 797	GB-A- 1 016 232
GB-A- 1 354 167	US-A- 3 045 613
US-A- 4 511 321	

- (73) Proprietor: Ivarson, Nemo  
Skönviksvägen 253  
S-122 42 Enskede(SE)
- (72) Inventor: Ivarson, Nemo  
Skönviksvägen 253  
S-122 42 Enskede(SE)
- (74) Representative: Uusitalo, Isak  
Carminger, Uusitalo & Nyberg Patentbyrå AB  
Box 19055 Surbrunnsgatan 32  
S-104 32 Stockholm(SE)

**EP 0 320 480 B1**

Note: Within nine months from the publication of the mention of the grant of the European patent, any person may give notice to the European Patent Office of opposition to the European patent granted. Notice of opposition shall be filed in a written reasoned statement. It shall not be deemed to have been filed until the opposition fee has been paid (Art. 99(1) European patent convention).

### Descripti n

The present invention relates to an apparatus which combines the steps of continuously mixing together powder and liquid ingredients, kneading the resultant mixture to form a compact plastic mass or dough and extruding said plastic mass to form elongated extrusions. The apparatus includes a mixer, a mixer housing, individual liquid and powder delivery conduits, and a mixture outlet. The mixing housing has arranged therein a horizontal wheel which is rotatable together with a vertically extending shaft in the mixer housing, and the liquid delivery conduit opens into a cavity located in the wheel, whereas the powder delivery conduit opens into a powder chamber located in the upper part of the horizontal wheel. The cavity communicates with the upper side of the wheel through a circumferentially extending slot or gap, which opens out adjacent a circumferentially extending edge located on the side of the slot or gap nearest the periphery of said wheel, said slot having substantially a frusto-conical configuration, with the apex of the cone facing downwards.

Various kinds of pellets are produced by first mixing a dry material with a binder dissolved in water or some other solvent, which will often be highly volatile, whereafter the resultant mixture is transferred to an extruder, in which the mixture is pressed, in various ways, through extrusion dies or orifices of different shapes and sizes.

Apparatus for continuously mixing liquid and powder material together so as to form a substantially homogenous mixture is previously known from Swedish Published Patent Specification 421 047. An apparatus for kneading a mixture and subsequent extrusion of the resultant plastic mass, a so-called extruder, is described and illustrated in EP-A-0163619.

When using these two known apparatus, the step of transferring the mixture to the extruder is always encumbered with handling problems, particularly when volatile solvents are used. In addition to engendering losses and creating problems environmentally, vaporization of the solvent present results in partial drying of the mixture, with subsequent disturbances in production, which results in extrusions of uneven quality.

The object of the present invention is to overcome this problem, by enabling the steps of mixing together the mixture ingredients and of kneading and extruding the resultant mixture to be carried out in one and the same apparatus, thereby obviating the need of using two separate apparatus, as required by the prior art techniques. The inventive apparatus is based on the apparatus described and illustrated in the prior published Swedish Specification No. 421 047, this known apparatus being modi-

fied in accordance with the inventive concept to include compacting, kneading and extruding facilities.

The inventive apparatus is characterized by the features set forth in the claims.

The invention will now be described in more detail with reference to an exemplifying embodiment thereof illustrated schematically in the accompanying drawings, in which Figure 1 is a vertical sectional view of the apparatus according to the invention; Figure 2 is a section taken on the line II-II in Figure 1; Figure 3 shows part of the section of Figure 2 in larger scale; and Figure 4 shows part of the section of Figure 1 in larger scale.

The illustrated apparatus includes a mixer housing 1 provided with a cover member 2. Arranged within the housing 1 is a wheel assembly which comprises an upper wheel 3 and a lower wheel 4, said wheels extending in the horizontal plane and said lower wheel including a hollow shaft 5 which is journaled in bearing 6 for rotation in the housing 1. Located between the upper and lower wheels 3 and 4 is a cavity 7 which communicates with the upper side of the upper wheel 3 through a circumferentially extending slot 8 which has a frusto-conical configuration, with the cone apex facing downwards. Blades 9 are mounted on the upper wheel 3. The blades 9 define therebetween spaces 10 which are intended to receive the powder ingredient of the mixture. Located on the lower wheel 4, adjacent the orifice of the slot 8, is a circumferentially extending chopper edge 11, and the lower wheel 4 carries on its peripheral surface blades or "baffles" 12, the outer edges 13 of which run adjacent to a conical surface 14 on the cover member 2. Extending circumferentially around the mixer housing is a recess which accommodates a perforated shell 15. The holes 16 of the shell 15 are of cylindrical configuration and the axes of respective holes form an angle  $\beta$  with the radius of the mixer housing, which lies between 0 and 90° and is, for instance 60°. The angle  $\alpha$  between the axes of the holes and the plane 17 of the orifices thereof is preferably about 90°. The powder ingredient is delivered to the mixer housing through a conduit 18 and the liquid ingredient is delivered through the cavity or hollow 19 in the hollow shaft 5.

In the preparation of a mixture, the wheel assembly 3, 4 rotates in the housing 1 at a speed of from 1000 to 5000 rpm. The liquid ingredient, or wet phase, is therewith delivered to the cavity 7 between said upper and lower wheels through the hollow tubular shaft 5. The liquid is thrown outwardly by the centrifugal force generated and passes through the slot 8, to form a liquid film or skin which expands constantly outwards while becoming thinner in the process. When the liquid film

leav s th slot 8 it strik s th chopper edge 11 and is therewith disint grated into microscopic dropl ts. so as to form a mist curtain. The powder ingredient is passed through the conduit 18 to the spac s 10 defined b tween mutually adjacent blades 9 at th same tim as the liquid ingredient is deliver d to the cavity 7, this powder ingredi nt b ing thrown outwardly by centrifugal force and the blades 9, towards the periphery of the upper wheel 3 while simultaneously being whipped-up and impinging with the mist curtain at the chopper edge 11. The two ingredients, or phases, are now slung outwardly together and collide against the conical surface 14 on the cover member 2, where they are instantaneously mixed together. The resultant mixture is immediately caught by the blades 12, the edges 13 of which pass immediately adjacent the conical surface 14 and knead and tear the mixture against said surface, in a process similar to that of kneading and rolling-out pastry dough. The mixtures is kneaded and rolled or spread down towards the perforated shell 15 while being formed into a compact, plastic mass. This plastic mass is subsequently pressed through the cylindrical holes 16 by the outer, leading edge 21 of the blades 12, these edges passing contiguously with the inner surface 22 of the shell 15, to form homogenous, compact elongated, cylindrical extrusions 20.

The holes 16 are formed at an angle  $\beta$  relative to the shell radius, which lies as close to a right angle as possible, so that the forces exerted by the blades are active as near as possible in the direction of the axes of said holes 16. This will reduce losses due to friction and also reduce the amount of heat generated during the actual moment of extruding the plastic mass.

The plane of the outlet orifices of respective holes 16 shall form with the axes of said holes an angle  $\alpha$  which is as near to a right angle as possible, so as to prevent the extrusions from being deflected against the outer surface of the shell, such deflection resulting in bending of the extrusions such as to form a porous and cracked outer surface which renders further processing of the extrusions difficult.

**Claims**

1. An apparatus for continuously producing a substantially homogenous mixture from liquid and powder ingredients, kneading such a mixture into a compact, plastic mass, and extruding the plastic mass to form elongated extrusions, said apparatus comprising a mixer, a mixer housing (1), mutually separate liquid delivery and powder delivery conduits (18, 19), a mixture exit, a wheel assembly comprising an upper (3) and a lower (4) part and being h ri-

zontal and mounted for rotation in the mixer housing on a vertical shaft (5), said liquid delivery conduit (19) opening into a cavity (7) located between the upper and lower part of the wheel, where as the powder delivery conduit (18) opens into powder-receiving spaces (10) defined by first blades (9) being vertically mounted on the upper part (3) of the wheel assembly and having a radial direction, and in which apparatus said cavity (7) communicates with the upper side of the wheel assembly via a circumferentially extending slot or gap (8) which opens out adjacent a chopper edge (11) located on the lower part (4) and extending circumferentially on the peripheral side of the slot or gap having a substantially frusto-conical configuration with the apex of the cone facing downwards, characterized by a cylindrical shell (15) which extends around the periphery of the mixer housing (1) and which is perforated with holes (16) over that part of its periphery which lies across the mixer housing exit and the axis of which shell is coaxial with the axis (5) of the mixer wheel assembly; and in that arranged between said chopper edge (11) and the cylindrical shell (15), in a direction of a chord in the mixer housing, are second blades (12) which are vertically mounted and connected with the lower wheel part (4) of the wheel assembly, and the outer extremities (21) of which are intended to sweep over the inner surface of the shell (15), and the edges (13) of which are contiguous with a frusto-conical surface (14) in the upper part of the mixer housing.

2. Apparatus according to Claim 1, characterized in that the axes of the holes (16) in the shell (15) form an angle  $\beta$  with the cylindrical shell radius which lies between 0° and 90°.
3. An apparatus according to Claim 2, characterized in that the orifices of respective holes (16) on the outer surface of the shell are configured so as to form substantially a right angle with the axes of respective holes.
4. An apparatus according to any of Claims 1 - 3, characterized in that the second blades (12) have a wedge-configuration in a projection on a horizontal plane in the mixer housing with the apex of the wedges facing inwardly in said housing (1).

**Patentansprüche**

1. Apparat zum kontinuierlichen Verfertigen einer im wesentlichen homogenen Mischung von

Flüssigkeit und pulverförmigen Bestandteilen. Kneten in einer solchen Mischung zu einer dichten, plastischen Masse und Extrudieren der plastischen Masse unter Ausbildung langgestreckter Stränge, mit einem Mischer, einem Mischergehäuse (1), voneinander getrennten Leitungen (18, 19) für das Zuführen von Flüssigkeit und Pulver, einem Mischungsausgang, einer Radanordnung mit oberem (3) und unterem (4) Teil und horizontal liegend und auf einer vertikalen Welle (5) im Mischergehäuse drehbar angeordnet, wobei sich die Flüssigkeitszuführleitung (19) in einen Hohlraum (7) öffnet, welcher zwischen dem oberen und dem unteren Teil des Rades gelegen ist, während sich die Pulverzuführleitung (18) in Pulver aufnehmende Zwischenräume (10) öffnet, welche durch erste Klingen (9) begrenzt sind, welche vertikal an dem oberen Teil (3) der Radanordnung sitzen und eine radiale Richtung haben, wobei der Hohlraum (7) mit der oberen Seite der Radanordnung über einen Umfangsschlitz oder -spalt (8) in Strömungsverbindung steht, welcher sich einem Hackmesserrand (11) benachbart öffnet, der an dem oberen Teil (4) gelegen ist, sich längs des Umfangs auf der peripheren Seite des Schlitzes oder Spaltes erstreckt und von der Gestalt eines Kegelstumpfes mit Scheitel nach unten ist, gekennzeichnet durch eine zylindrische Schale (15), welche sich um die Peripherie des Mischergehäuses (1) erstreckt und welche mit Löchern (16) über demjenigen Teil ihrer Peripherie perforiert ist, der dem Ausgang des Mischergehäuses gegenüberliegt und deren Achse koaxial mit der Welle (5) der Mischerradanordnung ist, und durch zweite Klingen (12), welche zwischen dem Hackmesserrand (11) und der zylindrischen Schale (15) in Richtung einer Sehne in dem Mischergehäuse vertikal angeordnet, mit dem unteren Radteil (4) der Radanordnung verbunden, mit ihren äußersten Enden (21) über die Innenfläche der Schale (15) streichen sollen und mit ihren Rändern (13) an eine kegelstumpfförmige Oberfläche (14) im oberen Teil des Mischergehäuses angrenzen.

2. Apparat nach Anspruch 1, dadurch gekennzeichnet, daß die Achsen der Löcher (16) in der Schale (15) mit dem Radius der zylindrischen Schale einen Winkel bilden, welcher zwischen 0° und 90° liegt.
3. Apparat nach Anspruch 2, dadurch gekennzeichnet, daß die Mündungen der jeweiligen Löcher (16) auf der äußeren Oberfläche der Schale derart gestaltet sind, daß sie im wesentlichen einen rechten Winkel mit den Ach-

sen der jeweiligen Löcher bilden.

4. Apparat nach einem der Ansprüche 1 bis 3, dadurch gekennzeichnet, daß die zweiten Klingen (12) eine Keilform in einer Projektion auf eine horizontale Ebene in dem Mischergehäuse haben, wobei die Spitze der Keile nach innen in das Gehäuse (1) weist.

## 10 Revendications

1. Appareil pour la production continue d'un mélange sensiblement homogène à partir d'un ingrédient liquide et d'un ingrédient en poudre, le pétrissage d'un tel mélange en une masse plastique compacte et l'extrusion de la masse plastique pour former des produits extrudés allongés, ledit appareil comprenant un mélangeur, un carter de mélangeur (1), des conduits mutuellement séparés (18,19) d'amené de liquide et d'amenée de poudre, une sortie d'mélange, un ensemble à roue comprenant une partie supérieure (3) et une partie inférieure (4) et étant horizontal et monté pour rotation sur un arbre vertical (5) dans le carter de mélangeur, ledit conduit d'amené de liquide (19) débouchant dans une cavité (7) située entre la partie supérieure et la partie inférieure de la roue, tandis que le conduit d'amené de poudre (18) débouche dans des espaces de réception de poudre (10) définis par des premières pales (9) montées verticalement sur la partie supérieure (3) de l'ensemble à roue et ayant une direction radiale, et, dans ledit appareil, la dite cavité (7) communique avec le côté supérieur de l'ensemble à roue par une fente ou intervalle (8) s'étendant circumférentiellement qui débouche près d'une arête de cisaillement (11) située sur la partie inférieure (4) et s'étendant circumférentiellement du côté périphérique de la fente ou intervalle présentant une configuration sensiblement tronconique avec le sommet du cône tourné vers le bas, caractérisé par une chemise cylindrique (15) qui s'étend autour de la périphérie du carter de mélangeur (1) et qui est percée de trous (16) sur la partie de sa périphérie qui se trouve sur la sortie du carter de mélangeur, l'axe de cette chemise étant confondu avec l'axe (5) de l'ensemble à roue de mélangeur ; et en ce que, entre ladite arête de cisaillement (11) et la chemise cylindrique (15), dans la direction d'une corde du carter de mélangeur, sont agencées des deuxième pales (12) qui sont montées verticalement et reliées à la partie de roue inférieure (4) de l'ensemble à roue, et dont les extrémités extérieures (21) sont prévues pour balayer la surface intérieure de la

chemise (15) et dont les bords (13) sont contigus à un surfac tronconique (14) de la partie supérieure du carter de mélangeur.

2. Appareil suivant la revendication 1, caractérisé en ce que les axes des trous (16) de la chemise (15) forment un angle  $\beta$  avec le rayon de la chemise cylindrique, cet angle étant compris entre  $0^\circ$  et  $90^\circ$ .
3. Appareil suivant la revendication 2, caractérisé en ce que les orifices de trous respectifs (16) sur la surface extérieure de la chemise sont configurés de manière à former sensiblement un angle droit avec les axes des trous respectifs.
4. Appareil suivant l'une quelconque des revendications 1 à 3, caractérisé en ce que les deuxièmes pales (12) ont une configuration en coin, dans une projection sur un plan horizontal dans le carter de mélangeur, le sommet des coins étant tourné vers l'intérieur dans ledit carter (1).

5

10

15

20

25

30

35

40

45

50

55

5

Fig. 1

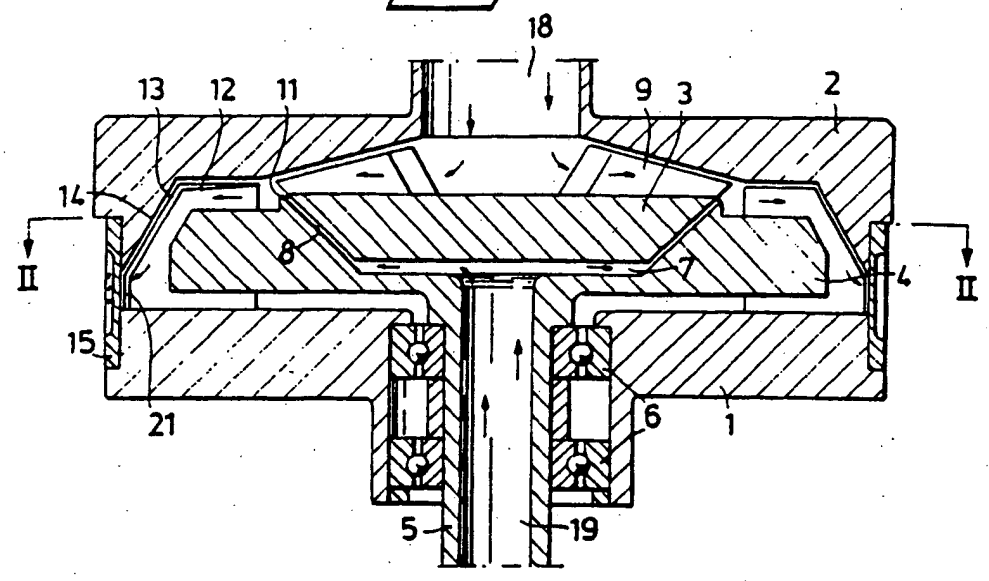

Fig. 2

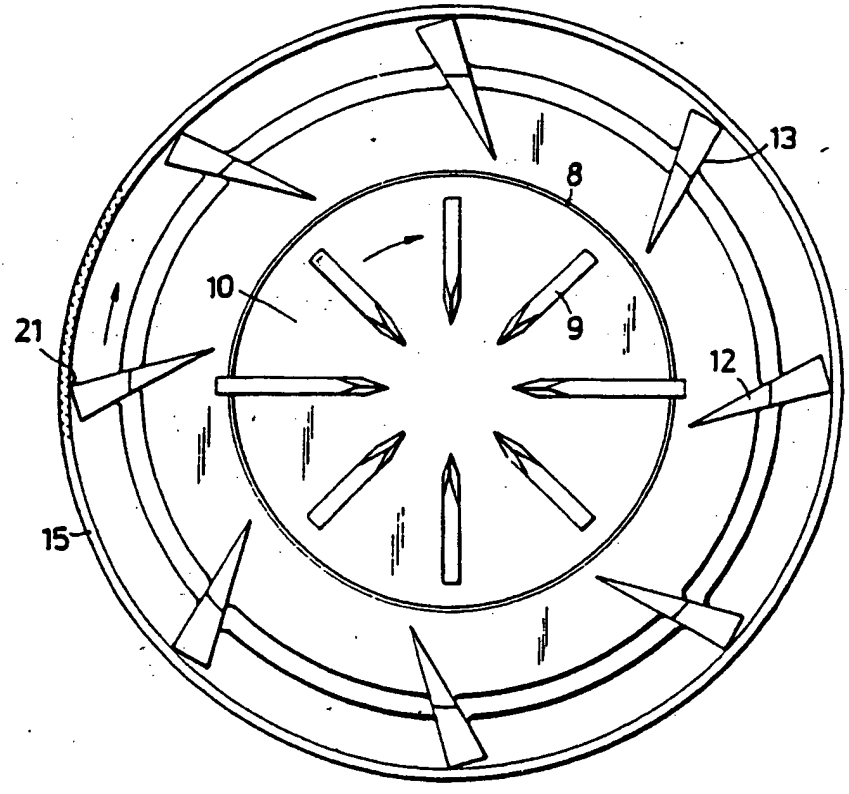

Fig. 3

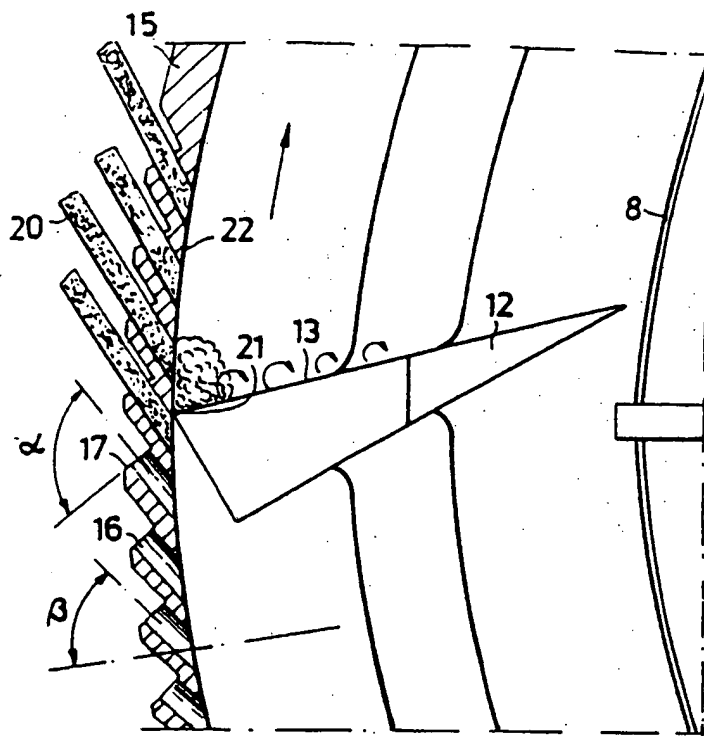

Fig. 4

